

INSTALLATION AND OPERATION INSTRUCTIONS

MODELS

**HS-NS, HS-NSPC,
HS-WS-50, HS-WS-50D,
HS-WS-50/192**

TRANSDUCERS

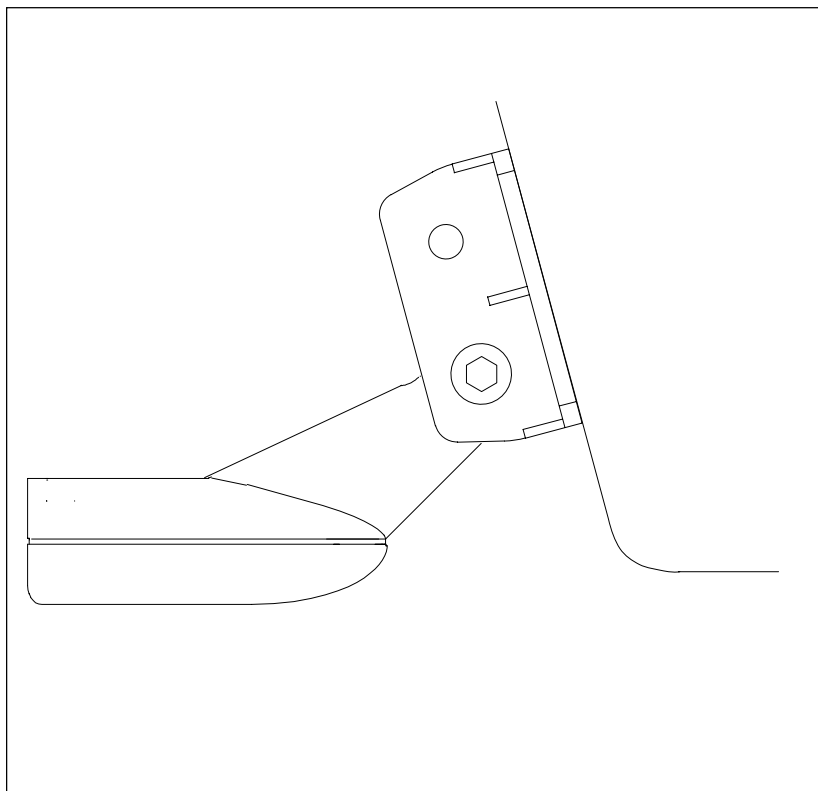

LEI
ACCESSORIES
FOR LOWRANCE, EAGLE, AND SEA ELECTRONICS PRODUCTS

The HS-NS and HS-NSPC are 192 kHz, 8 degree cone angle transducers. The HS-WS-50 and HS-WS-50D are 50 kHz, 36 degree cone angle transducers. The HS-WS-50/192 is a dual frequency transducer with 192 kHz, 20 degree and 50 kHz, 36 degree cone angle elements. All are transom mount transducers. They can be installed on any outboard or stern-drive powered boat. Do not use these transducers on an inboard powered boat. The HS-NSPC has a power cable attached to the connector. Follow the installation instructions for the power cable on the back of this manual. Please install the HS-NSPC transducer before wiring it's power cable.

Please read these instructions carefully before installing your transducer. The transducer mounting location is the most critical part of a sonar installation. If it isn't done properly, the sonar can't perform to its potential.

ASSEMBLY

1. Locate the four ratchets in the transducer's hardware package. Note there are letters engraved into one side of each ratchet. These are for the coarse angle adjustment. A standard transom angle is 14 degrees. By aligning a letter on the ratchet to the alignment mark on the the transducer bracket, the correct transducer angle can be attained. Once you've determined the correct angle, press one ratchet on each side of the transducer and one ratchet on each transducer bracket as shown below.

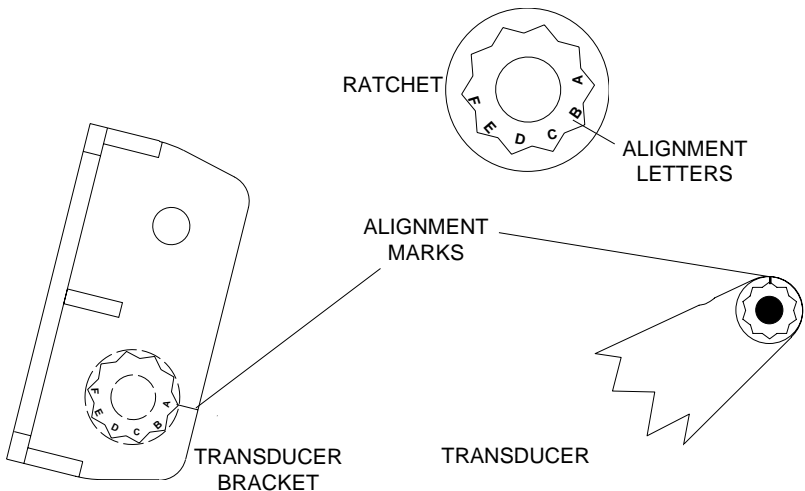

TRANSDUCER BRACKET

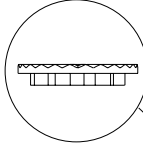
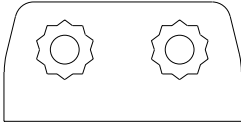

RATCHET

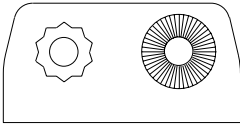
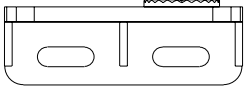

TRANSDUCER

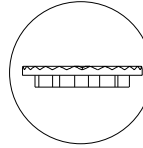
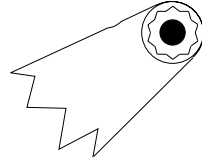

RATCHET

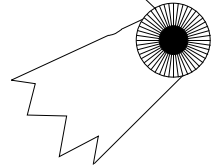

See the chart at the top of the next page for example transducer angles for letter "A" at 12, 14, and 16 degree transom angles.

14 DEGREES

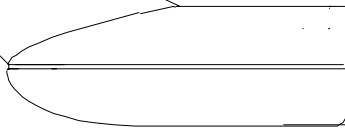
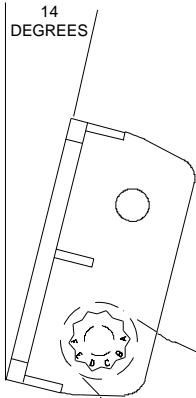

-° ANGLE OF ATTACK
+°

This is the way the transducer should look when it's mounted on the transom.

12 DEGREE TRANSOM ANGLE

INDEX MARKS	A-A	A-B	A-C	A-D	A-E
	+37.0	+31.0	+40.0	+35.0	+28.0
ANGLE OF ATTACK	+22.0	+16.0	+25.0	+20.0	+13.0
IN DEGREES	+6.0	-1.0	+10.0	+4.0	-2.0
(REF. BOTTOM OF HULL) PER RATCHET CLICK	-9.0	-14.0	-5.0	-11.0	-17.0

14 DEGREE TRANSOM ANGLE

INDEX MARKS	A-A	A-B	A-C	A-D	A-E
	+39.0	+33.0	+42.0	+37.0	+30.0
ANGLE OF ATTACK	+24.0	+18.0	+27.0	+22.0	+15.0
IN DEGREES	+8.0	+3.0	+12.0	+6.0	0.0
(REF. BOTTOM OF HULL) PER RATCHET CLICK	-7.0	-12.0	-3.0	-9.0	-15.0

16 DEGREE TRANSOM ANGLE

INDEX MARKS	A-A	A-B	A-C	A-D	A-E
	+41.0	+35.0	+44.0	+39.0	+32.0
ANGLE OF ATTACK	+26.0	+20.0	+29.0	+24.0	+17.0
IN DEGREES	+10.0	+5.0	+14.0	+8.0	+2.0
(REF. BOTTOM OF HULL) PER RATCHET CLICK	-5.0	-10.0	-1.0	-7.0	-13.0

14 DEGREE
TRANSOM
ANGLE

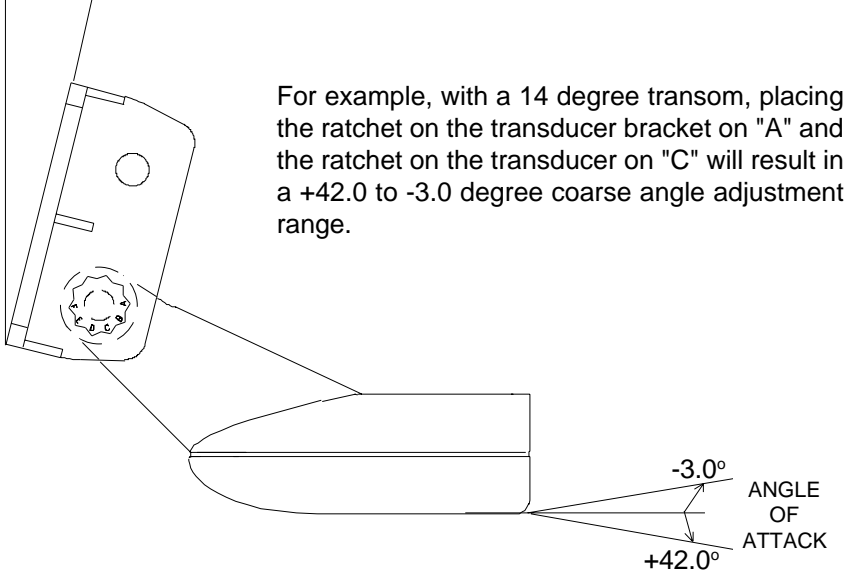

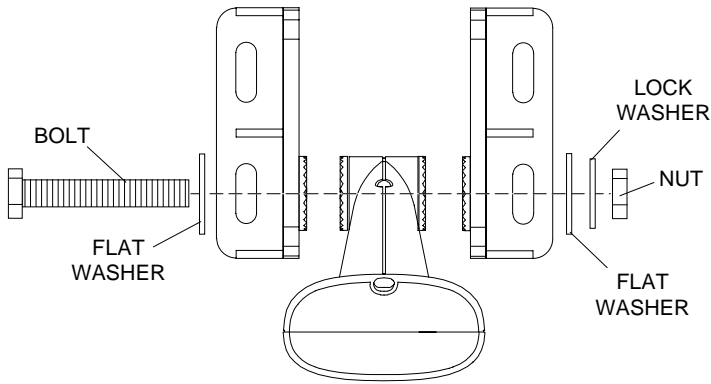

2. Once you've determined the proper ratchet placement, assemble the transducer and bracket as shown above. Don't tighten the nut at this time.

INSTALLATION - Location

1. The transducer must be placed in a location that has a smooth flow of water at all times. Air bubbles created by the movement of the boat hull against the water interfere with the sonar signal. This causes "noise" or random marks to appear on the sonar's display. You may need to carefully view the water's path at the transom while the boat is moving to determine the best location for the transducer.
2. Make certain the chosen location doesn't interfere with the boat's trailer. Mount the transducer at least one foot from the engine's lower unit. This will prevent air bubbles from the transducer interfering with the propeller.

CAUTION!
CLAMP THE TRANSDUCER CABLE TO
TRANSOM NEAR THE TRANSDUCER. THIS
WILL HELP PREVENT THE TRANSDUCER
FROM ENTERING THE BOAT IF IT IS
KNOCKED OFF AT HIGH SPEED.

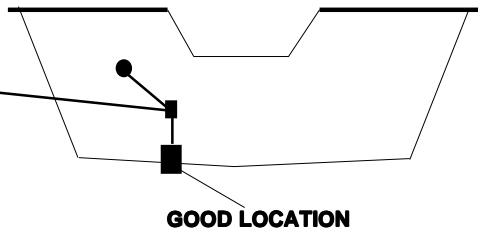

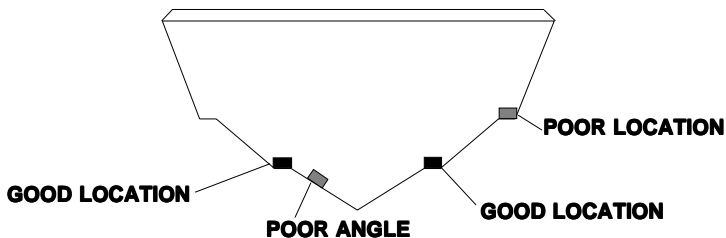

3. Don't mount the transducer directly behind strakes or ribs on the bottom of the hull. Typically, a good location on aluminum boats is between the ribs closest to the engine.
4. Once you determine the best location for the transducer, hold the bracket against the transom. The transducer should be roughly parallel to the ground. The bottom of the hull should be about halfway between the centerline of the transducer and its bottom. (See the illustration below.)

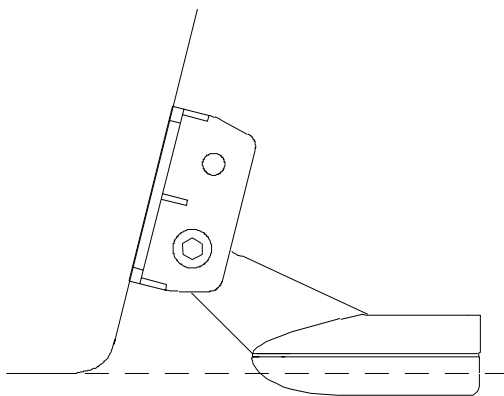

Mark the transom in the center of each slot in the transducer bracket. Now drill one hole in the center of each slot. Use #12 stainless steel screws (not included) to loosely attach the brackets to the transom.

5. Adjust the transducer and bracket so that the front of the transducer is slightly lower than the back. See the section on fish arches in this manual for proper transducer angles. Tighten all screws. Clamp the transducer cable to the transom close to the transducer. This will prevent the transducer from entering the boat should it be knocked off at high speed.

6. Route the transducer cable to the sonar unit. Keep the transducer cable away from other wiring on the boat, if possible. Electrical noise from engine wiring or bilge pumps can be picked up on the transducer cable. This can show up as unwanted interference on the sonar display.

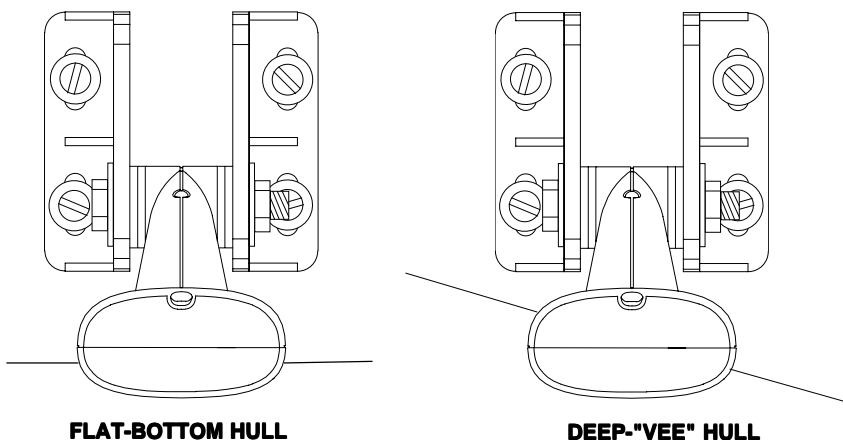

NOTE: Some aluminum boats with strakes or ribs on the outside of the hull create large amounts of turbulence at high speed. These boats typically have large outboard motors capable of propelling the boat at speeds over 35 mph. The transducer should be mounted as far below the hull as possible on these boats. This will place the face of the transducer below the turbulent water, allowing the sonar unit to work at high speeds.

7. Make a test run to determine the results. If there is interference on the display when running the boat at high speed, try lowering or changing the angle of the transducer.

NOTE

Periodically wash the transducer's face with soap and water to remove any oil film. Oil and dirt on the face will reduce the sensitivity or may even prevent operation.

CAUTION!

MAKE CERTAIN TO CLAMP THE TRANSDUCER CABLE TO THE TRANSOM NEAR THE TRANSDUCER. THIS WILL HELP PREVENT THE TRANSDUCER FROM ENTERING THE BOAT IF IT IS KNOCKED OFF AT HIGH SPEED.

POWER CONNECTIONS - HS-NSPC ONLY

NOTE! INSTALL THE TRANSDUCER BEFORE MAKING THE POWER CONNECTIONS!

The sonar unit works from a 12 volt DC system only. For the best results, run the power cable directly to the boat's battery. Keep the power cable away from other boat wiring, especially the engine's wires. This will give the best isolation from electrical noise. If the supplied cable is not long enough to reach the battery, splice #18 gauge insulated wire to it. You can attach the power cable to an accessory or power buss, however, you may have problems with electrical interference. Make certain to attach the in-line fuse holder to the positive lead as close to the battery or terminal strip as possible. This will protect both the unit and the power cable in the event of a short.

WARNING!

Do not use this product without a 3-amp fuse wired into the power cable! Failure to use a 3-amp fuse will void your warranty!

This unit has reverse polarity protection. No damage will occur if the power wires are reversed. However, the unit will not work until the wires are attached correctly.

